

BRINKMANN®

Solar Gallery™

**SOLAR
MAX.**

EXTRA-LONG RUNNING SOLAR POWERED ACCENT LIGHTS

**POST LIGHT™
OWNER'S MANUAL**

ASSEMBLY AND OPERATING INSTRUCTIONS



HOW YOUR POST LIGHT™ SOLAR-POWERED L.E.D. LIGHTS WORK

**⚠ READ AND FOLLOW ALL INSTRUCTIONS CAREFULLY BEFORE OPERATING YOUR SOLAR LIGHT.
SAVE THIS MANUAL FOR FUTURE REFERENCE.**



IMPORTANT:

The EPA Certified RBRC® Battery Recycling Seal on the nickel-cadmium (Ni-Cd) battery contained in our product indicates The Brinkmann Corporation is voluntarily participating in an industry program to collect and recycle these batteries at the end of their useful life, when taken out of service in the United States or Canada. The RBRC® program provides a convenient alternative to placing used Ni-Cd batteries into the trash or the municipal waste stream, which may be illegal in your area. Please call 1-800-8-BATTERY™ for information on Ni-Cd battery recycling and disposal bans/restrictions in your area. The Brinkmann Corporation's involvement in this program is part of our commitment to preserving our environment and conserving our natural resources.

During the day, the solar panel converts sunlight into electricity and recharges the battery. At night, the light turns on automatically using the electricity stored during that day.

The number of hours the light will stay on is dependent on your geographical location, weather conditions and seasonal lighting availability.

Solar lights do not receive as much direct sunlight in winter months. Therefore, the number of hours the light will stay on will be reduced during winter.

1

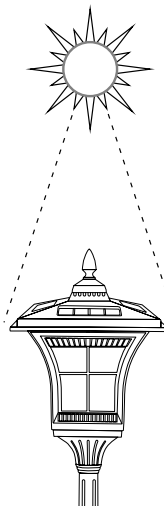

BEFORE FIRST USE – Pull out to remove the clear plastic strip with orange sticker in the light fixture to charge batteries.

Your new solar light's rechargeable Ni-Cd battery is fully charged and ready for use. Install the solar light in direct sunlight. For optimum performance, it is best to charge the solar light for a **FULL, SUNNY DAY**. The light will turn on automatically at night. The Ni-Cd rechargeable battery provides increased brightness and stays on longer as it cycles over time (days and nights of charging and discharging). The more direct sunlight that the light receives during the day, the brighter and longer the light will stay on at night.

The rechargeable Ni-Cd battery must be allowed to fully charge to operate properly. Partially charging the battery on a consistent basis will drastically reduce the life of the battery.

ASSEMBLY INSTRUCTIONS

Inspect contents of the box to ensure all parts are included and undamaged.

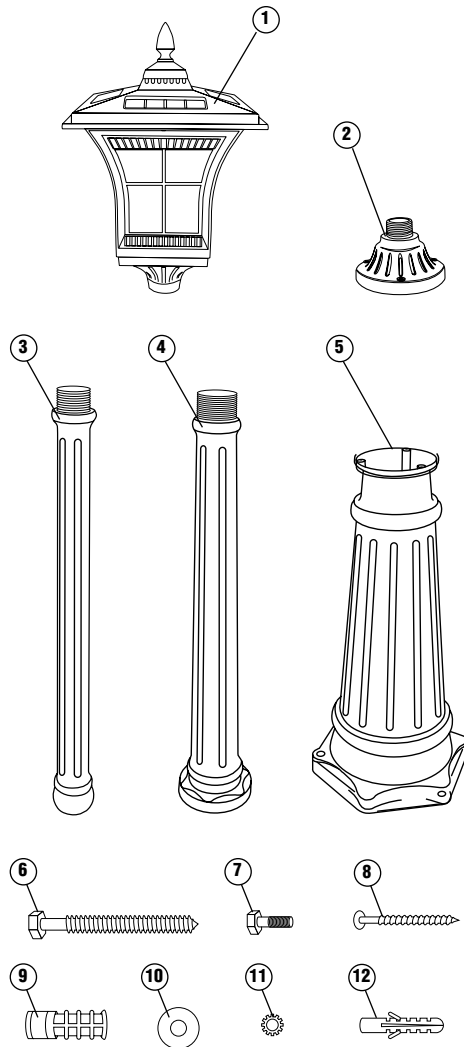

PARTS LIST:

- ① Post Light Light Head Fixture
- ② Top Mounting Stand
- ③ Post Top Section
- ④ Post Middle Section
- ⑤ Post Base Section
- ⑥ 3 - Lag Screws (Post Base)
- ⑦ 3 - 6 X 20MM Bolts (Post Middle)
- ⑧ 3 - Lag Screws (Top Mounting Stand)
- ⑨ 3 - Expansion Shields (Post Base)
- ⑩ 3 - Washers (Post Base)
- ⑪ 3 - Washers (Post Middle)
- ⑫ 3 - Expansion Shields (Top Mounting Stand)

Select a location with **FULL, DIRECT SUNLIGHT**. Shady locations will not allow the battery to charge fully and will reduce the hours of nighttime light.

NOTE: The rechargeable Ni-Cd battery must be allowed to fully charge to operate properly. Partially charging the battery on a consistent basis will drastically reduce the life of the battery.

The selected location should **not** be near a nighttime light source such as a porch light or street light, as these might keep the solar lights from automatically turning on. The solar lights should not be placed closer than 5 feet from one another. This could cause the solar lights to flicker from the adjacent light source.

OPERATING INSTRUCTIONS

**▲ READ AND FOLLOW ALL INSTRUCTIONS CAREFULLY BEFORE OPERATING YOUR SOLAR LIGHT.
SAVE THIS MANUAL FOR FUTURE REFERENCE.**

POST LIGHT ASSEMBLY

Step 1

Refer to included template sheet for proper clearances, bolt pattern and base mounting instructions.

Step 2

With base section firmly mounted, attach the middle section of post using three 6 X 20MM bolts and washers.

Step 3

Screw top section of post onto middle section.

Step 4

Screw light head fixture onto top section of post.

Step 5

For optimum performance, it is best to charge the solar light for a **FULL, SUNNY DAY**. The light will turn on automatically at night. The Ni-Cd rechargeable battery provides increased brightness and stays on longer as it cycles over time (days and nights of charging and discharging). The more direct sunlight that the light receives during the day, the brighter and longer the light will stay on at night.

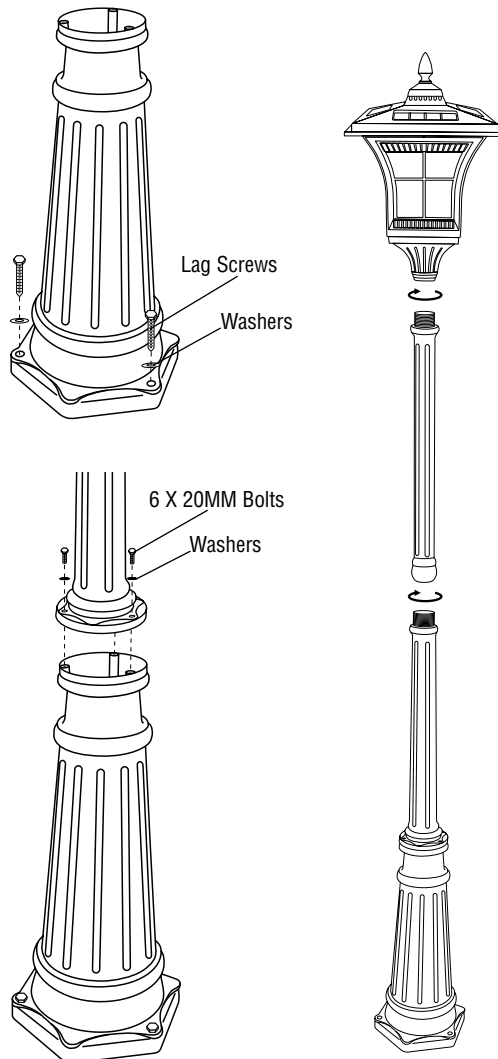

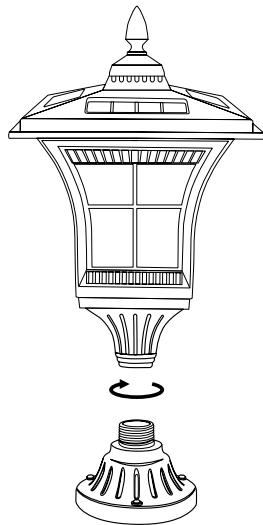
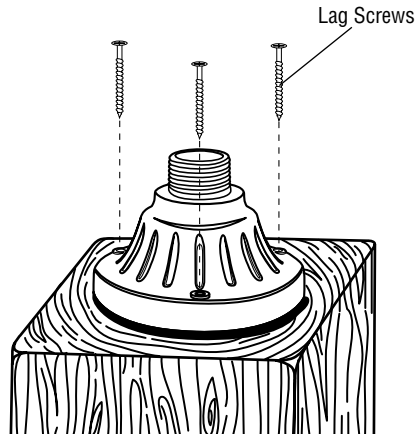

TOP MOUNTING STAND ASSEMBLY

Step 1

Refer to included template sheet for proper clearances bolt pattern and top mounting stand instructions.

Step 2

With stand firmly mounted, screw light head fixture onto top of mounting stand.

Step 3

For optimum performance, it is best to charge the solar light for a **FULL, SUNNY DAY**. The light will turn on automatically at night. The Ni-Cd rechargeable battery provides increased brightness and stays on longer as it cycles over time (days and nights of charging and discharging). The more direct sunlight that the light receives during the day, the brighter and longer the light will stay on at night.

Changing Battery

Step 1

Remove lens from top housing by turning lens clockwise.

Step 2

With top housing upside down (solar panel facing down), pinch tabs on sides of reflector and lift reflector off top housing. Push tabs on battery compartment lids and remove the lids.

Step 3

Remove batteries. Replace with new Ni-Cd rechargeable batteries.

Step 4

Replace battery compartment lids.

Step 5

Attach the lens by aligning the tabs with the slots in top housing. Turn counter-clockwise to lock in place.

NOTE: This light utilizes L.E.D. (Light Emitting Diode) technology. There are no bulbs to replace.

Cleaning

It is important that the solar panel is kept free of dirt and debris. A dirty solar panel will not allow the battery to fully charge. This will shorten the life of the battery and cause the light to malfunction. Clean regularly with a dampened cloth or paper towel.

5



IMPORTANT:

The EPA Certified RBRC® Battery Recycling Seal on the nickel-cadmium (Ni-Cd) battery contained in our product indicates The Brinkmann Corporation is voluntarily participating in an industry program to collect and recycle these batteries at the end of their useful life, when taken out of service in the United States or Canada. The RBRC® program provides a convenient alternative to placing used Ni-Cd batteries into the trash or the municipal waste stream, which may be illegal in your area. Please call 1-800-8-BATTERY™ for information on Ni-Cd battery recycling and disposal bans/restrictions in your area. The Brinkmann Corporation's involvement in this program is part of our commitment to preserving our environment and conserving our natural resources.

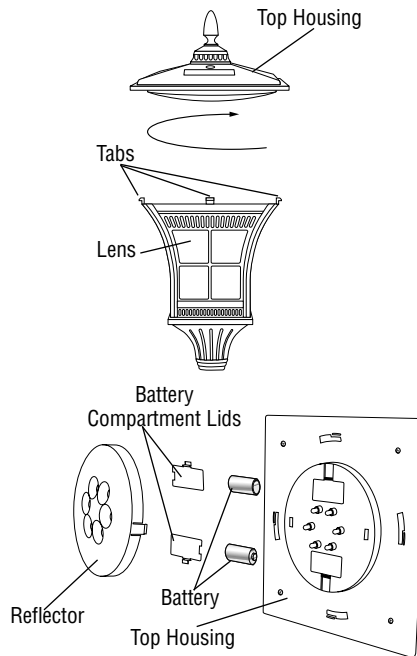

Storage Tips

Solar lights can be left outside year round, even in cold weather. However, if you wish to store your light indoors for more than two or three days, follow these steps to prevent damage to rechargeable batteries:

- Store at room temperature in a dry location.
- Store solar light where it can receive some sunlight or room light each day. The battery needs light to maintain a charge during storage.
- During prolonged storage, units must be fully discharged and charged once every month or remove batteries and replace with new Ni-Cd rechargeable batteries when ready for use. Check and replace batteries periodically throughout the year.
- Do not store solar lights in a box, or a dark room without a source of light on the solar panel. This will damage the batteries and prevent their ability to hold a charge.
- For best performance, do not store for prolonged periods.

Troubleshooting Information

If your solar light does not turn on at night, it may be caused by one the following conditions:

- Battery is not fully charged or needs replacement:
 - a. Make sure your light is located in an area where the solar panel gets the maximum amount of **FULL, DIRECT SUNLIGHT** every day.
 - b. If the weather has been cloudy or overcast during the day, the battery will not be recharged for operation at night. The solar light must have direct sunlight every day to fully charge the battery. If the solar light does not receive enough sunlight one day, it will recharge the next sunny day and resume normal operation.
 - c. Check and replace the battery periodically throughout the year, especially after winter months. Replacement batteries may be purchased from The Brinkmann Corporation Customer Service Department by calling 1-800-468-5252.
- Other light sources: If your solar lights are located too close to a street light, porch light or another solar light, it may not turn on automatically at night. The built-in photocell light sensor is reacting to the other light source. Eliminate the other light source or relocate your solar lights.
- Dirty solar panel: A dirty solar panel will not allow the battery to fully charge. This will shorten the life of the battery and cause the light to malfunction. Clean regularly with a dampened cloth or paper towel.

After correcting the problem, check the light operation immediately after dark or in a dark room. If the light will only operate for a short time, the battery needs recharging.

Wintertime Tips

- Clean snow and debris off the solar panel to allow battery to recharge.
- Check and replace battery periodically throughout the year, especially after winter months.

©2003 The Brinkmann Corporation
Dallas, Texas 75244 U.S.A
www.brinkmanncorp.com

2-YEAR LIMITED WARRANTY

For 2-years from date of purchase, The Brinkmann Corporation warrants the Post Light solar light against defects due to workmanship or materials to the original purchaser. The Brinkmann Corporation's obligations under this warranty are limited to the following guidelines:

- This warranty does not extend to the L.E.D. or batteries.
- This warranty does not cover solar lights that have been altered or damaged due to: normal wear, abuse, improper maintenance, improper use, disassembly of parts and/or attempted repair by anyone other than an authorized employee of The Brinkmann Corporation.
- This warranty does not cover surface scratches or weathering as this is considered normal wear.
- Warranty service is limited to repair or replacement of solar lights which prove defective under normal use and which upon examination shall indicate to Brinkmann's satisfaction, they are defective. If Brinkmann confirms the defect and approves the claim, Brinkmann will elect to repair or replace the solar light as covered by the terms of this warranty.
- This warranty extends to the original purchaser only and is not transferable or assignable to subsequent purchasers.

The Brinkmann Corporation requires reasonable proof of purchase. Therefore, we strongly recommend that you retain your sales receipt or invoice. To obtain repair or replacement of your Post Light solar light under the terms of this warranty, please call Customer Service Department at 1-800-527-0717 for a **Return Authorization Number** and further instructions. **A receipt or proof of purchase will be required.** Solar lights returned to Brinkmann must include your name, address and telephone number. Please make sure the light is properly packed, postage prepaid, and insured. **A Return Authorization Number must be clearly marked on the outside of the box.** Brinkmann cannot be responsible for any solar lights forwarded to us without a Return Authorization Number.

EXCEPT AS ABOVE STATED, THE BRINKMANN CORPORATION MAKES NO OTHER EXPRESS WARRANTY.

THE IMPLIED WARRANTIES OF MERCHANTABILITY AND FITNESS FOR A PARTICULAR PURPOSE ARE LIMITED IN DURATION TO 2-YEARS FROM THE DATE OF PURCHASE. SOME STATES DO NOT ALLOW LIMITATIONS ON HOW LONG AN IMPLIED WARRANTY LASTS, SO THE ABOVE LIMITATION MAY NOT APPLY TO YOU.

ANY LIABILITY FOR INDIRECT, INCIDENTAL OR CONSEQUENTIAL DAMAGES ARISING FROM THE FAILURE OF THE POST LIGHT SOLAR LIGHT TO COMPLY WITH THIS WARRANTY OR ANY IMPLIED WARRANTY IS EXCLUDED. CUSTOMER ACKNOWLEDGES THAT THE PURCHASE PRICE CHARGED IS BASED UPON THE LIMITATIONS CONTAINED IN THE WARRANTY SET OUT ABOVE. SOME STATES DO NOT ALLOW THE EXCLUSION OR LIMITATION OF INCIDENTAL OR CONSEQUENTIAL DAMAGES, SO THE ABOVE LIMITATION OR EXCLUSION MAY NOT APPLY TO YOU. THIS WARRANTY GIVES YOU SPECIFIC LEGAL RIGHTS, AND YOU MAY ALSO HAVE OTHER RIGHTS WHICH VARY FROM STATE TO STATE.